



Tetra[®] PowerMAX

CHANNEL LETTER LIGHTING SYSTEMS

With powerful OptiLens™ X
and groundbreaking energy
efficiency

Tetra[®]PowerMAX — the 24V remarkable LED system designed for channel letters as shallow as 4 inches in depth, as well as cabinet signs, delivers incredibly uniform light, installs easily and operates efficiently. **Tetra[®]PowerMAX** is now IP66 and UL wet rated which makes it more robust and reliable than ever, even under wet weather.

Powerful OptiLens™ X

Tetra® PowerMAX features OptiLens™ X, our patented technology that allows for an incredible 170° viewing angle. This exclusive technology redirects otherwise wasted light to the sign face, making sure your signs shine.

Power Supply Loading

Now load up to 68.6 feet (20.9 m) or 103 modules of 24V **Tetra® PowerMAX** per 100W power supply using our new and improved GLX2 power supplies.

Improved stroke spacing

24V **Tetra® PowerMAX** stroke spacing has improved on average by 35% compared to the 12V version (Depth/Stroke Spacing 4"/14", 5"/17", 6"/22"), requiring less product thanks to the OptiLens™ X wide beam angle.



Tetra® PowerMAX Features

- Wide 170° beam angle
- Improved luminous intensity
- Efficacy: 158 lm/W
- 24 Volt DC, Class 2 (UL), Class III (IEC)
- UL Wet Rated & IP66
- 10-year limited warranty

Tetra® PowerMAX Spacing

	Can Depth	Coverage
Medium	4-5" (102-127mm)	14" (355.6mm)
	5-6" (127-152mm)	17" (431.8mm)
Large	≥ 6" (152mm)	22" (558.8mm)

Total Reliability

To ensure every **Tetra® PowerMAX** installation will operate brilliantly for years, we perform the most extensive, stringent testing in the industry. We test the LED, water and dust ingress protection, sub-system and complete system at our in-house and independent laboratories around the world. Validation of our designs, components, products and processes include high temperature, high humidity and accelerated life testing.



Mechanical Outline & Viewing Angle

Dimensions in (inches). Metric equivalent mm

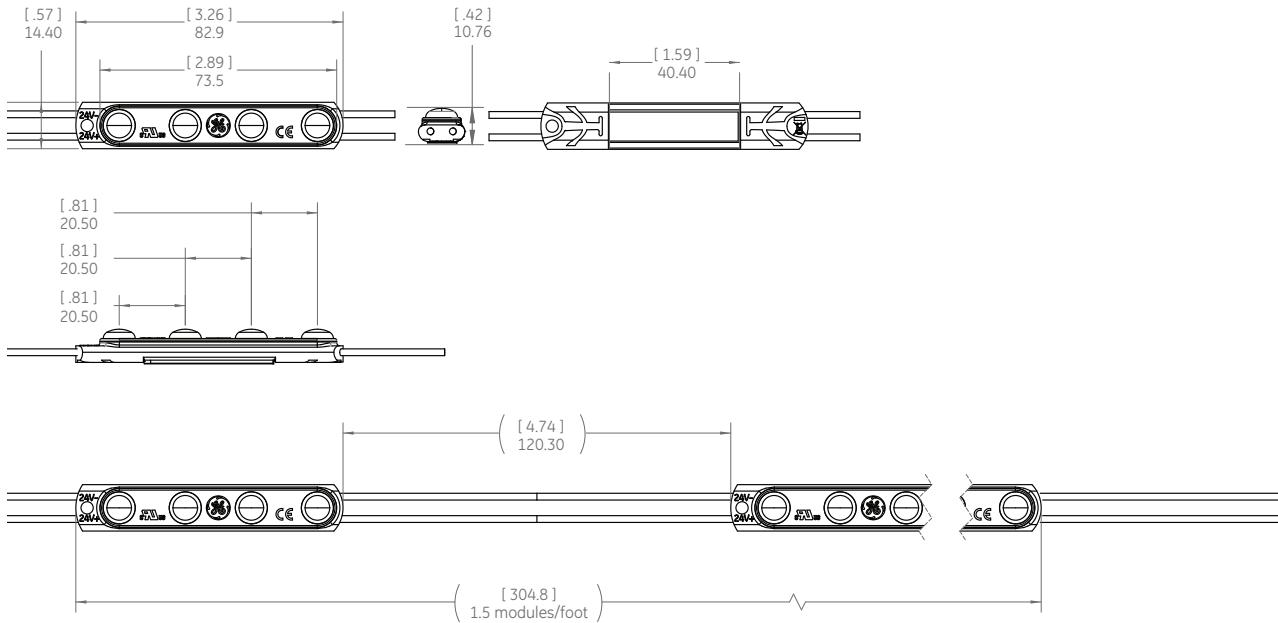

Viewing angles

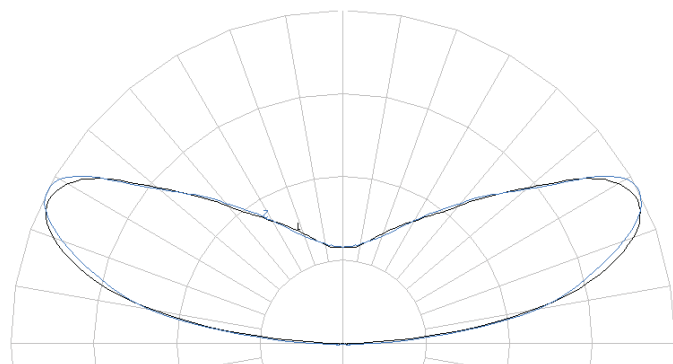

Accessories

SKU	Description	Package quantity
GETMEC1	18 AWG Wire End Caps (0.82 mm ²)	100/bag
9409	18 AWG Supply Wire (0.82 mm ²)	500 ft (152.40m)/spool
191600041	22-14 AWG Twist-on Wire Connector (0.33-2.08 mm ²)	500/bag
192160004	18-14 AWG In-line Splice Connector (0.82-2.08 mm ²)	500/bag

Components

SKU	Model	Details	Color	Pkg. Quantity	Modules per strip
93051997	GEPM2471-W1	Tetra® PowerMAX 24V 7100K	White	5 Strips/Box	30 modules per strip (20 ft/strip)
93118729	GEPM2465-W1	Tetra® PowerMAX 24V 6500K	Warm White	5 Strips/Box	30 modules per strip (20 ft/strip)
93118730	GEPM2457-W1	Tetra® PowerMAX 24V 5700K	Warm White	5 Strips/Box	30 modules per strip (20 ft/strip)
93051998	GEPM2450-W1	Tetra® PowerMAX 24V 5000K	Warm White	5 Strips/Box	30 modules per strip (20 ft/strip)
93051999	GEPM2441-W1	Tetra® PowerMAX 24V 4100K	Warm White	5 Strips/Box	30 modules per strip (20 ft/strip)
93052000	GEPM2432-W1	Tetra® PowerMAX 24V 3200K	Warm White	5 Strips/Box	30 modules per strip (20 ft/strip)

Technical Specifications

Model	Wavelength/ CCT	Typical Brightness Lumens/ module	Typical Brightness Lumens/Ft (Lumens/m)	Energy Consumption Module Wattage	Energy Consumption System Wattage	100W GLX Power Supply Loading	100W GLX2/ TT Power Supply Loading	Viewing Angle
GEPM2471-W1	7100K	133	200 (656)	0.84w/module	0.988w/module	64 ft (19.5 m)	68.6 ft (20.9 m)	170°
GEPM2465-W1	6500K	133	200 (656)	0.84w/module	0.988w/module	64 ft (19.5 m)	68.6 ft (20.9 m)	170°
GEPM2457-W1	5700K	133	200 (656)	0.84w/module	0.988w/module	64 ft (19.5 m)	68.6 ft (20.9 m)	170°
GEPM2450-W1	5000K	133	200 (656)	0.84w/module	0.988w/module	64 ft (19.5 m)	68.6 ft (20.9 m)	170°
GEPM2441-W1	4100K	133	200 (656)	0.84w/module	0.988w/module	64 ft (19.5 m)	68.6 ft (20.9 m)	170°
GEPM2432-W1	3200K	120	180 (590)	0.84w/module	0.988w/module	64 ft (19.5 m)	68.6 ft (20.9 m)	170°

Additional Specifications

Dimmable	Yes (with dimmable power supply)				
LEDs/Module	4				
LEDs/ft (LEDs/m)	6 (19.7)				
Modules/ ft. (Modules/m)	1.5 (4.9)				
Cutting Resolution	Cut on wire between every module				
Power Supply	GEPS24-25-NA Input: 100-305VAC; Output: 24VDC GEPS24D-80U Input: 90-305VAC; Output: 24VDC GEPS24-100U Input: 108-305VAC; Output: 24VDC GEPS24-200U Input: 90-305VAC; Output: 24VDC GEPS24-300U Input: 108-305VAC; Output: 24VDC				
Maximum Supply Wire Limits		18 AWG/0.82 MM² Supply Wire	16 AWG/1.31 MM² Supply Wire	14 AWG/2.08 MM² Supply Wire	12 AWG/3.31 MM² Supply Wire
	25W Power Supply	120 ft./36.6 m	/	/	/
	80W Power Supply	20 ft./6.1 m	25 ft./7.6 m	35 ft./10.6 m	40 ft./12.1 m
	100W Power Supply	20 ft./6.1 m	25 ft./7.6 m	35 ft./10.6 m	40 ft./12.1 m
	200W Power Supply	20 ft./6.1 m	25 ft./7.6 m	35 ft./10.6 m	40 ft./12.1 m
300W Power Supply	20 ft./6.1 m	25 ft./7.6 m	35 ft./10.6 m	40 ft./12.1 m	
Operating Environment	-40 °C to +60 °C (-40 °F to +140 °F)				
Module Dimensions (h x l x w)	.42" x 3.26" x 0.57" (10.76 mm x 82.9 mm x 14.4 mm)				
Warranty	Limited system warranty of up to ten (10) years				
System Certifications	UL Recognized (C-US) #E219167, UL Classified (C-US) #E229508, CE, ROHS • IP66 rated: for dry, damp or wet location.				