

G2G ArRay 2

Sign Cabinet Solutions

Specifications

Viewing Angle	170° Optics
Input Voltage	12VDC
Watts	SF 1W/mod, DF 1.8W/mod
Lumen	100lm/mod(SF), 200lm/mod(DF)
Colors	7000K
Modules/Foot	3mods/sq.ft
Protection Grade	IP67
Packaging	60pcs/case
Warranty	5 Year (Product) / 1 Year (Labor)
Operating Temp.	-40°~ +60 °C / -40° ~ +140 °F
Storage Temp.	-40°~ +70 °C / -40° ~ +158 °F

Drawings

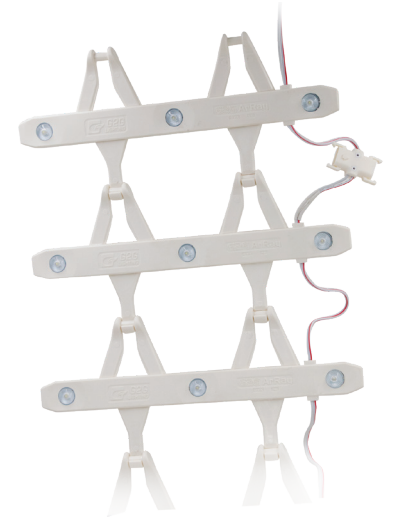
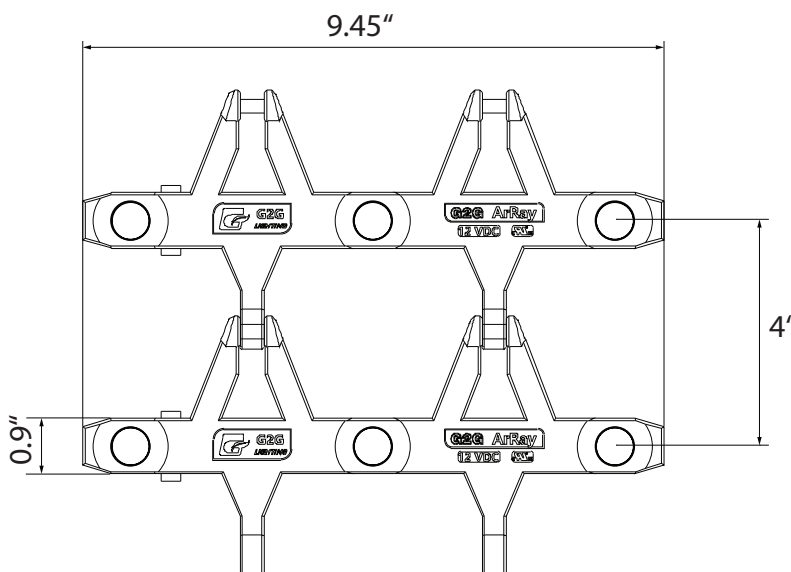

IP67



Benefits

- Quick Installation System (QIS) enabled.
- Designed for sign cabinets.
- UV and IR Protected
- L80 rating of 50,000 hours
- 3M double face tape and mechanical mounting options.



800.253.1569 | wensco.com

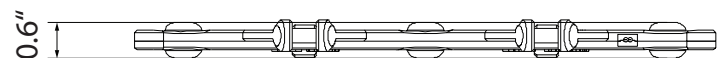

(Unit: inch)